

## **03. TECHNICAL SPECIFICATIONS**

# 1 SPECIFICATIONS OF THE HEAVY DUTY D TYPE HAWSER SHACKLE

Variations and/or deviations from specification, if any, shall be illustrated clearly in detail. Complete technical specification details shall also provide together with following.

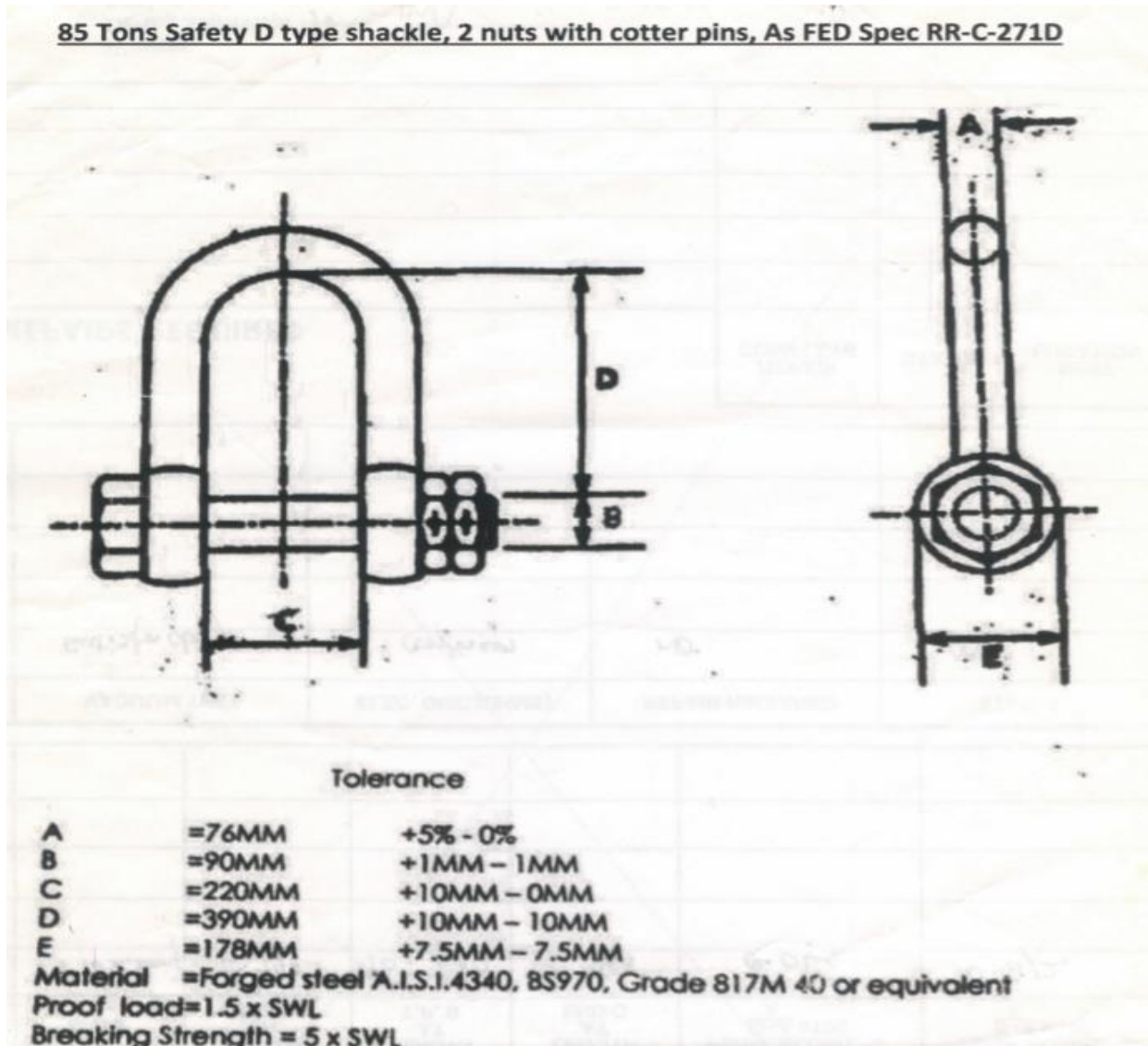

## Other Conditions

- Warranty period and conditions shall be specified clearly on the offer.
- Item manufacturing shall be in accordance with FED Spec RR-C-271D or equivalent and compatible to use with Chafe Chain A&B.
- A certified copy of proof load test certificate of prototype item to be provided with the bid.
- A original proof load test certificates certified by recognize third party inspector for items to be provided along with the items
- Recent customer list shall be attached with the offer.

Signature of the Bidder: ..... Date:.....

(Common Company Seal)